



ET 20T

Case Erector Bottom Sealer

- Heavy duty construction
- Interlocked safety guarding
- UL approved main control enclosure
- Single point air / electrical hook up
- Powder Coated Finish
- Positive Hand Crank Adjustments
- Stainless steel construction with Nema 4 or Nema 4X
- Low Tape / No Tape/ Low Hopper
- Food grade grease
- Remote stop

MARQ
PACKAGING SYSTEMS

A division of Marquis Operating Limited Partnership

Proudly
Associated With:



The operator friendly design of the ET Series case erector features an easily adjustable hand crank system that utilizes easy to read ruler scales for precise adjustments. Cases are picked from the bottom of the shuttle hopper and enter the set-up section to be erected. From there the top and bottom lugs drive the erected case forward folding the minor & major flaps. As the case exits the forming section it is passed through the tape head sealing the bottom before exiting the machine.

Standard Features

- Wiring practices conform to NFPA standards
- Operator friendly design
- Quick changeover
- Fully guarded
- Continuous feed hopper
- UL508A listed electrical panels

Operational Requirements



FOOTPRINT

TOP VIEW

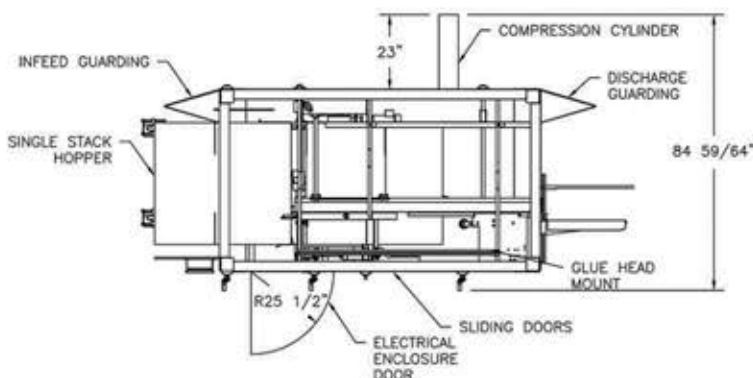

SIDE VIEW

