



HPA-LL

*Automatic Case Sealer With Lid
Lifter for 2-Piece HSC Cases*

- Frame is 3/16" steel construction
- Closes and seals a wide range of case sizes
- Designed for 24/7 operation
- Can be sealed with hotmelt glue, tape or a combination of both
- Right-hand or left-hand controls available
- Easily adjustable
- Hand crank or motorized adjustments

MARQ
PACKAGING SYSTEMS

A division of Marquis Operating Limited Partnership

Proudly
Associated With:



MARQ's Packaging's uniform case sealer with lid lifter has been designed for the fruit and vegetable industries to fold and seal the top of an HSC case without damage to overpack product.

This sealer will hold the outer half-slotted case with MARQ's mechanical lid lifters while the inner HSC case is gently lowered so that the major and minor flaps can be folded without any damage to the product. It utilizes both a split bottom belt and side belt conveying system which ensure accurate and square sealing of all cases.

Talk to a MARQ representative to see why this machine could work best for your application.

Standard Features

- Wiring practices conform to NFPA standards
- Operator friendly design
- Quick changeover
- Fully guarded
- Continuous feed hopper
- UL508A listed electrical panels

Operational Requirements



**THREE
PHASE**



**230/460
VOLTS AC**

FOOTPRINT

TOP VIEW

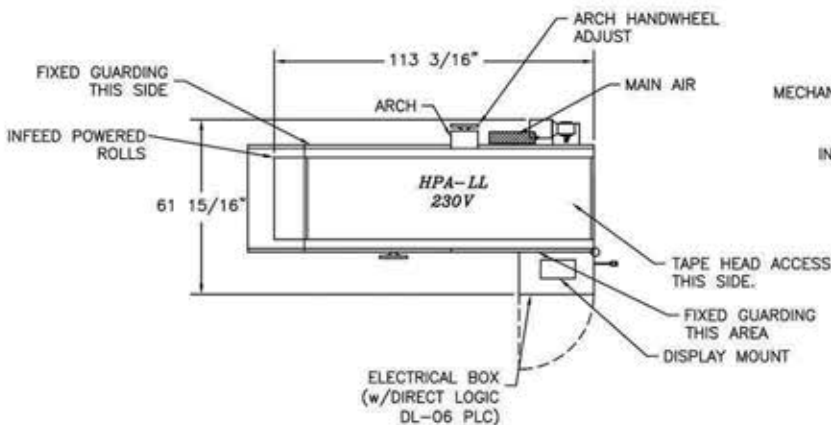

SIDE VIEW

