



HPR-E-SLD

*Random Height Top & Bottom
Case Sealer*

- Frame is 3/16" steel construction
- Powder coated finish
- Designed for 24/7 operation
- Polycarbonate guarding package (Custom design requests also available)
- Closes and seals a wide range of case sizes
- Top only or top and bottom
- Spring loaded side lug drive
- Right-hand or left-hand controls available

MARQ
PACKAGING SYSTEMS

A division of Marquis Operating Limited Partnership

Proudly
Associated With:



MARQ's Random Height and Top & Bottom Case Sealer is in a class all its own. This machine will run a selected range of random case heights, automatically adjusting for each new height by using a bar code reader or light curtain depending on the customer's case range. The light curtain senses the case's height, sending the data to the servo axis as the machine adjusts accordingly.

Quick enough to accommodate high volumes yet gentle enough to not crack even one egg this machine will seal your cases securely to protect your delicate cargo for shipping. This case sealer gives you the option of running "batch" mode (reaching speeds of up to 30 cases per minute depending on size) or "random" mode (speeds of 20 plus cases per minute). This machine has the ability to top and bottom seal and is built to withstand 24/7/365 operation.

Talk to a MARQ representative to see why this machine could work best for your application.

FOOTPRINT

Standard Features

- Wiring practices conform to NFPA standards
- Operator friendly design
- Quick changeover
- Fully guarded
- Continuous feed hopper
- UL508A listed electrical panels

Operational Requirements



THREE
PHASE



230/460
VOLTS AC

TOP VIEW

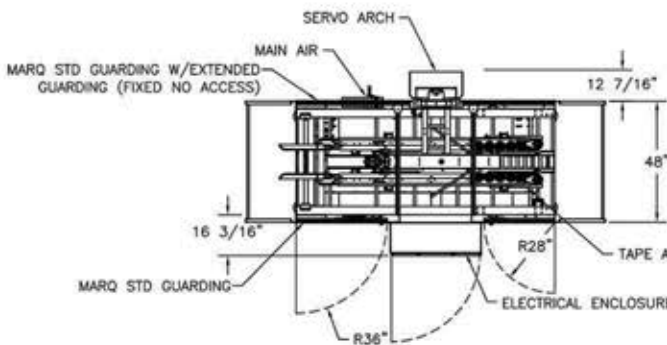

SIDE VIEW

