



HPR-SLD

*Random Case Sealer
with Side Lug Drive*

- Frame is 3/16" steel construction
- Side lug drive system
- Designed for 24/7 operation
- Powder coat finish
- Polycarbonate guarding package (Custom design requests also available)
- Closes and seals a wide range of case sizes
- Can be sealed with hotmelt glue, tape or a combination of both
- Right-hand or left-hand controls available
- Can run "batch" mode for high-speed applications

MARQ
PACKAGING SYSTEMS

A division of Marquis Operating Limited Partnership

Proudly
Associated With:



Eliminate your need for a uniform sealer at the end of each production line by investing in a MARQ Random Sealer. Our random sealers are built with high-end servo actuator technology and provide consistent accuracy within mere millimeters.

Our High Performance Random Case Sealer will close and seal up to 20 cases per minute. Side lugs convey each case evenly and accurately through the machine where minor and major flaps are folded and sealed. Available in your choice of tape or glue sealing, this machine will seal top only or top and bottom.

MARQ random sealers are offered in 75" and 102" frame sizes and are built to withstand the daily rigors of 24/7 operation.

Talk to a MARQ representative to see why this machine could work best for your application.

Standard Features

- Wiring practices conform to NFPA standards
- Operator friendly design
- Quick changeover
- Fully guarded
- Continuous feed hopper
- UL508A listed electrical panels

Operational Requirements



**80
PSI**



**THREE
PHASE**



**230/460
VOLTS AC**

FOOTPRINT

TOP VIEW

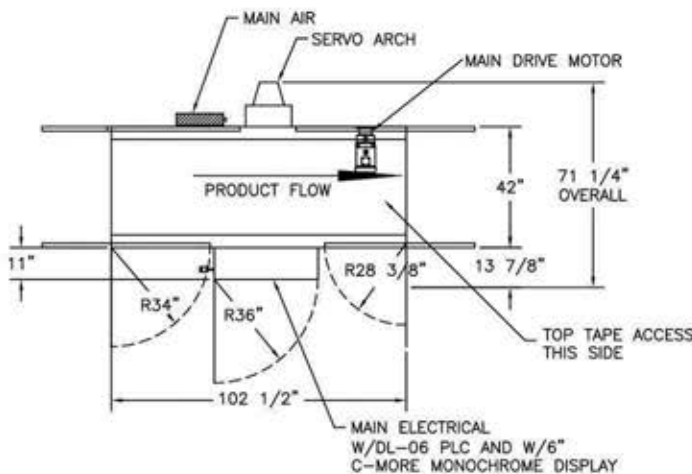

SIDE VIEW

