



HPT-S

Trayformer (Protein Industry)

- Frame is 3/16" steel construction
- Corrosion resistant components
- Trays feed automatically from single-stack hopper
- Polycarbonate guarding package
(Custom design request also available)
- Powder-coated finish
(Stainless steel upgrade available)
- Form trays from corrugated blanks
- Designed for 24/7 operation
- Glue sealing
- Right-hand or left-hand controls available

MARQ
PACKAGING SYSTEMS

A division of Marquis Operating Limited Partnership

Proudly
Associated With:



MARQ Packaging offers you a trayformer with a small footprint and high performance output. Easy-load hopper allows for effortless loading of tray blanks with no overhead lifting. Its continuous feed action eliminates downtime by allowing the operator to easily replenish the tray blanks load while the machine is running. There is no need to stop the machine in order to restock the hopper.

Positive top vacuum infeed helps to alleviate problems caused by warped corrugated. Trays enter the forming section in the horizontal position, glue is applied precisely with quick-shutoff heads, and the finished tray is released from the machine ready to use.

This machine will produce 30 trays per minute, and high-speed-upgrades are available. Forming section changeovers is estimated at 5 minutes. Standard features include a 6" color touch screen with PLC for quick and easy programming of tray-to-tray parameters, and an optional glue maintenance package with stack beacon to alert the operator of low glue, when glue has reached the desired temperature, or when the hopper is low on blanks.

Clear polycarbonate guarding doors open horizontally to provide easy access to the machine's components. Its compact footprint and streamlined styling makes this trayformer an excellent fit for nearly any space. Talk to a MARQ representative to see why this machine could work best for your application.

FOOTPRINT

Standard Features

- Wiring practices conform to NFPA standards
- Operator friendly design
- Quick changeover
- Fully guarded
- UL508A listed electrical panels

Operational Requirements



THREE
PHASE



230/460
VOLTS AC

TOP VIEW

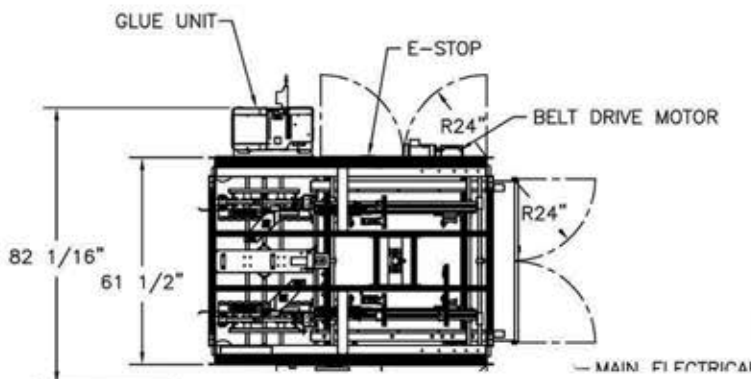

SIDE VIEW

